

8

7

6

5

4



3

2

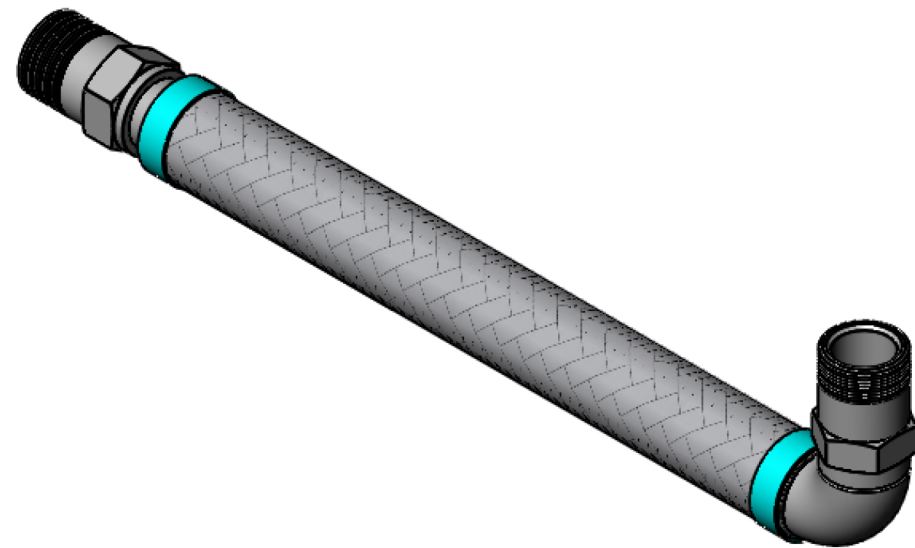
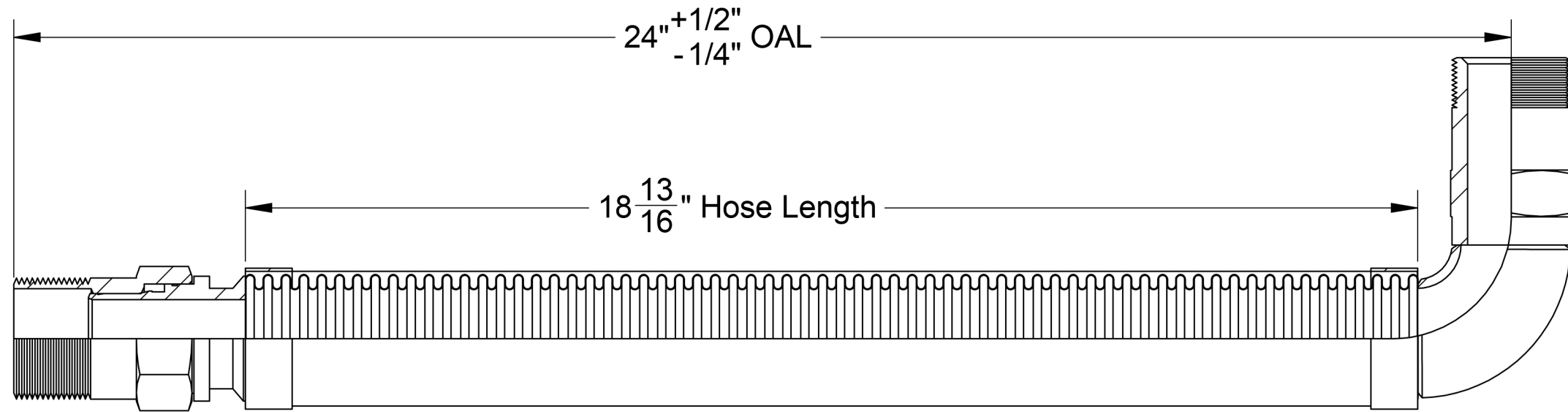
1



ITEM #	QTY.	PART NUMBER	DESCRIPTION	MATERIAL	WEIGHT
1	1	HOSE	300 Series Stainless HYDROFORMED Corrugated Hose	Stainless Steel	0.80
2	1	BRAID	300 Series Stainless Steel	Stainless Steel	0.07
3	2	BRAID COLLAR	0.05" Thick	Stainless Steel	0.07
4	1	1.5" ELBOW	1.5" Short Radius Elbow, Sch. 40	Carbon Steel	0.52
5	1	1.5" MALE	1.5" Male, 1-1/2"x11-1/2" Thread, 1.94" Hex	Carbon Steel	1.13
6	1	1.5" MALE SWIVEL	1.5" Male Swivel, 1-1/2"x11-1/2" Thread, 1.94" Hex	Carbon Steel	1.40

		<b>HOSE MASTER Inc.</b> 1233 East 222nd Street • Cleveland, Ohio 44117 (800) 221-2319 • Fax: (216) 481-7557 • www.hosemaster.com Locations: <b>Cleveland • Houston</b>		Registered to: ISO 9001 : 2000
				
Customer: Hose Master Inc.		Prepared By: <b>kannk</b>		Reference: Fire-Shield - 1.5" Male Swivel x 1.5" 90 Degree Male x 24 " OAL
Description: <b>1.5" ID x 24" OAL 300 Series Stainless HYDROFORMED Corrugated Hose covered by 300 Series Stainless Braid. UL Approved 1.5" Male Swivel Connector x 1.5" ID 90 Degree Male Connector</b>		CALC. WEIGHT: <b>4 lbs.</b>	Date: <b>9/24/2009</b>	
Drawing #: <b>FSSME0150x24</b>		Rev.: <b>-</b>	SHEET <b>1 OF 1</b>	

REVISIONS			
REV.	DESCRIPTION	DATE	APPROVED

8

7

6

5

4

3

2

1